

use & care guide

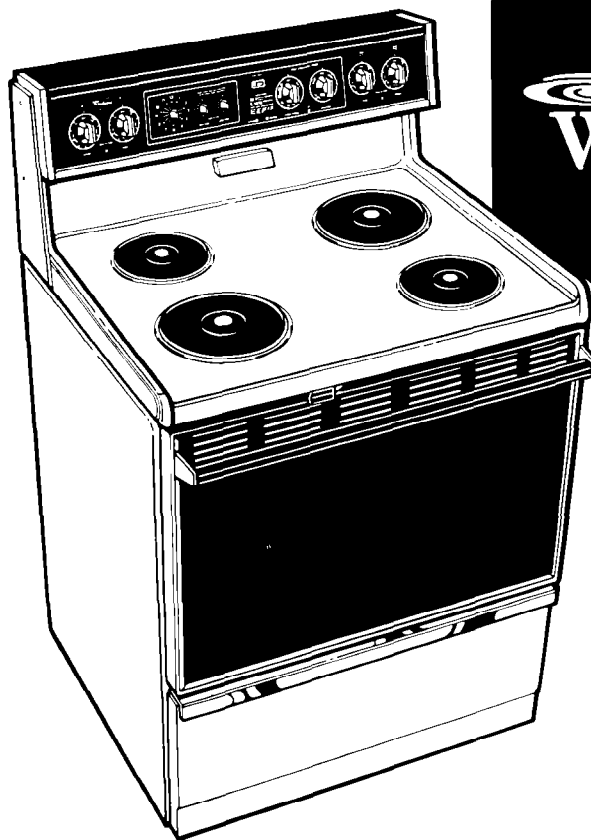

The Whirlpool logo, consisting of a stylized swirl above the word "Whirlpool" in a serif font.

ELECTRIC RANGE

Self-Cleaning
Models
RF377PXW
(Shown)
RF367BXW

ishers. Clothes Dryers. Freezers. Refrigerator-Freezers. Ice Makers. Dishwashers. Built-In Ovens and Surface Units. Ranges. Microwave Ovens. Trash Compact

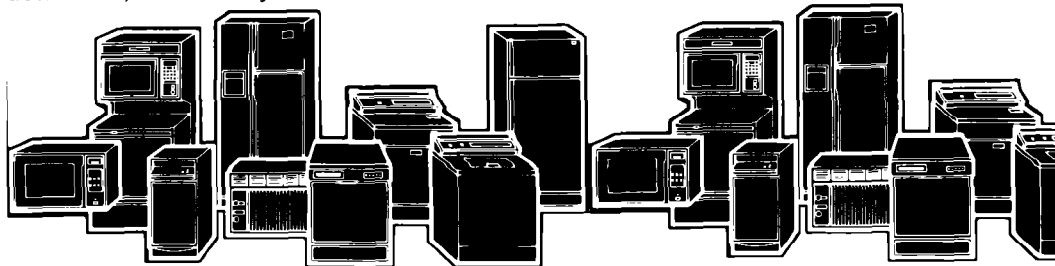

Contents

	Page		Page
BEFORE YOU USE YOUR RANGE	2	The Oven Vent	13
IMPORTANT SAFETY		The Storage Drawer	14
INSTRUCTIONS	3	Optional Rotisserie	15
PARTS AND FEATURES	5	Optional Door Panel Pac	15
USING YOUR RANGE	6	CARING FOR YOUR RANGE	15
Using the Surface Units	6	Control Panel and Knobs	15
Setting the Clock	8	Solid Element Surface Units	16
Using the Minute Timer	8	Using the Self-Cleaning	
Using the Oven Controls	9	Cycle	17
Baking	9	Cleaning Chart	20
Adjusting the Oven		The Oven Light	21
Temperature Control	10	IF YOU NEED SERVICE	
Broiling	11	OR ASSISTANCE	22
Custom Broil	11	WHIRLPOOL RANGE	
Using the Automatic		WARRANTY	24
MEALTIMER™ Clock	12		

©1990 Whirlpool Corporation

Before you use your range

You are responsible for:

- Reading and following all safety precautions in this Use and Care Guide and the Cooking Guide.
- Installing and leveling the range on a floor strong enough to hold its weight, and where it is protected from the elements. (See the Installation Instructions.)
- Making sure the range is not used by anyone unable to operate it properly.
- Properly maintaining the range.
- Using the range only for jobs expected of a home range.

Remove the Consumer Buy Guide label. It will be easier to remove before the range is used. To remove any remaining glue:

- Rub briskly with thumb to make a ball, then remove.
- or
- Soak area with liquid hand dishwashing detergent before removing glue as described above.

Do not use sharp instruments, rubbing alcohol, flammable fluids or abrasive cleaners. These can damage the finish. See "Important Safety Instructions" on page 3.

IMPORTANT SAFETY INSTRUCTIONS

⚠ WARNING

To reduce the risk of fire, electrical shock, injury to persons, or damage when using the range, follow basic precautions, including the following:

- Read all instructions before using the range.
- Install or locate the range only in accordance with the provided Installation Instructions. It is recommended that the range be installed by a qualified installer. The range must be properly connected to electrical supply and grounded.
- Do not use the range for warming or heating the room. Persons could be burned or injured, or a fire could start.
- Do not leave children alone or unattended in area where the range is in use. They should never be allowed to sit or stand on any part of the range. They could be burned or injured.
- Do not wear loose or hanging garments when using the range. They could ignite if they touch a hot surface unit or heating element and you could be burned.
- Do not repair or replace any part of the range unless specifically recommended in this manual. All other servicing should be referred to a qualified technician.
- Do not store flammable materials in or near the range. They could explode or burn.
- Do not use water on grease fires. Never pick up a flaming pan. Smother flaming pan on cooktop by covering with a well-fitted lid, cookie sheet or flat tray. Flaming grease outside of pan can be extinguished with baking soda or, if available, a multipurpose dry chemical or foam-type extinguisher.
- Use only dry potholders. Moist or damp potholders on hot surfaces may result in burns from steam. Do not let potholder touch hot heating elements. Do not use a towel or bulky cloth for a potholder. They could catch on fire.
- Select a pan with a flat bottom that is about the same size as the surface unit. If pan is smaller than the surface unit, some of the heating element will be exposed and may result in the igniting of clothing or potholders. Correct pan size also improves cooking efficiency.
- Never leave surface units unattended at high heat settings. A boil-over could result and cause smoking and greasy spill-overs that may ignite.
- Check to be sure glass cooking utensils are safe for use on the cooktop. Only certain types of glass, glass ceramic, ceramic, earthenware or other glazed utensils are suitable for cooktops without breaking due to the sudden change in temperature.
- Turn pan handles inward, but not over other surface units. This will help reduce the chance of burns, igniting of flammable materials, and spills due to bumping of the pan.
- Use care when opening oven door. Let hot air or steam escape before removing or replacing food.
- Do not heat unopened containers. They could explode. The hot contents could cause burns and container particles could cause injury.

- Keep range vents unobstructed.
- Always position oven racks in desired location while oven is cool. If rack must be moved while oven is hot, do not let potholder contact hot heating element in oven.
- Do not clean door seal. It is essential for a good seal. Care should be taken not to rub, damage, or move the seal. Clean only parts recommended in this Use and Care Guide.
- Do not use oven cleaners. No commercial oven cleaner or oven liner protective coating of any kind should be used in or around any part of the oven.
- Before self-cleaning the oven, remove broiler pan, broiler grid, oven racks and other utensils. Do not use your oven to clean miscellaneous parts.
- Do not store things children might want above the range. Children could be burned or injured while climbing on it.
- Do not touch surface units, areas near units, heating elements or interior surfaces of oven. Surface units and heating elements may be hot even though they are dark in color. Areas near surface units and interior surfaces of an oven become hot enough to cause burns. During and after use, do not touch, or let clothing or other flammable materials contact surface units, areas near units, heating elements or interior surfaces of oven until they have had sufficient time to cool. Other surfaces of the range may become hot enough to cause burns; such as, the oven vent opening, the surface near the vent opening, the cooktop, the oven door and window.

• **FOR YOUR SAFETY** •

DO NOT STORE OR USE GASOLINE OR OTHER FLAMMABLE VAPORS AND LIQUIDS IN THE VICINITY OF THIS OR ANY OTHER APPLIANCE. THE FUMES CAN CREATE A FIRE HAZARD OR EXPLOSION.

– **SAVE THESE INSTRUCTIONS** –

Thank you for buying a Whirlpool appliance. Please complete and mail the Owner Registration Card provided with this product. Then complete the form below. Have this information ready if you need service or call with a question.

- Copy model and serial numbers from plate (behind the oven door on the oven frame) and purchase date from sales slip.
- Keep this book, the Cooking Guide and sales slip together in a handy place.

Model Number

Serial Number

Purchase Date

Service Company Phone Number

Parts and features

Models RF377PXW (Shown)
& RF367BXW

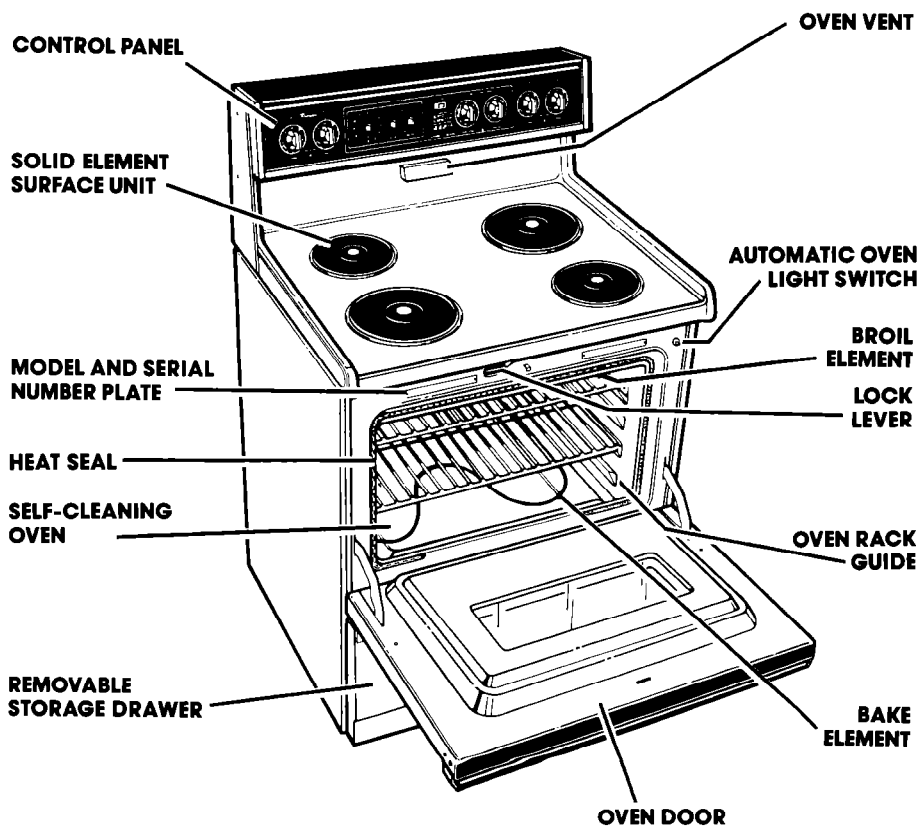
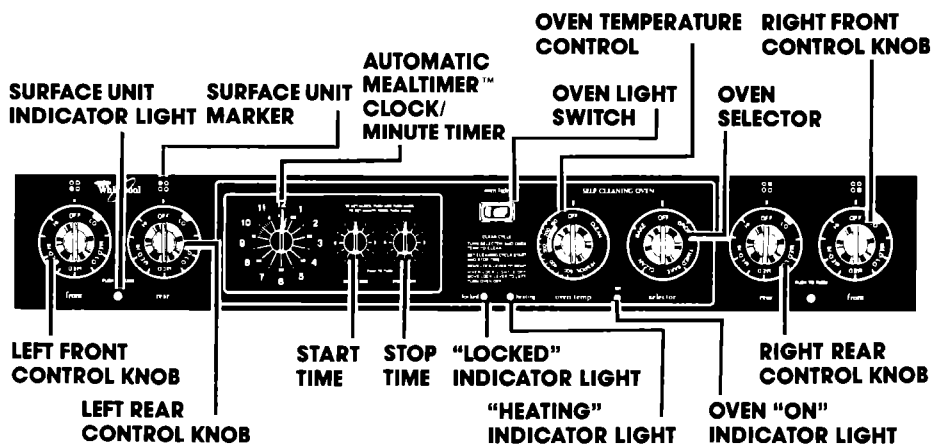

Using your range

Using the Surface Units

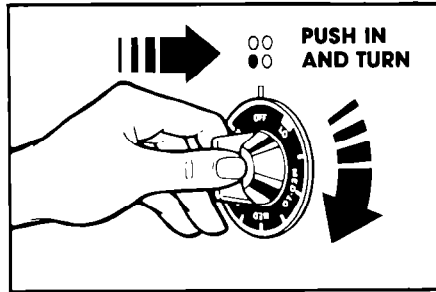

Control knobs must be pushed in before turning them to a setting. They can be set anywhere between HI and OFF.

Until you get used to the settings, use the following as a guide. For best results, start cooking at the high settings; then turn the control knob down to continue cooking.

Use HI to start foods cooking; to bring liquids to a boil.

Use MED-HI to hold a rapid boil; to fry chicken or pancakes.

Use MED for gravy, puddings and icing; to cook large amounts of vegetables.

Use MED-LO to keep food cooking after starting it on a higher setting.

Use LO to keep food warm until ready to serve. Set the heat higher or lower within the LO band to keep food at the temperature you want.

Surface Unit Markers

The solid dot in the surface unit marker shows which surface unit is turned on by that knob.

Surface Unit Indicator Lights

One of the surface unit indicator lights on the control panel will glow when a surface unit is on.

Solid element surface units

Before using a solid element surface unit for the first time, heat on HI setting for five minutes. The surface units will give off smoke as the protective coating, applied at the factory, finishes bonding to the surface.

Solid element surface units are made of heavy cast-iron to provide even cooking. Each surface unit has a built-in protective limiter as a safety feature. The limiter senses uneven cooking temperatures and automatically reduces the heat level. The limiter will sense uneven heat when a pan boils dry or when a pan is removed and the surface unit is left on. The heat level may also be reduced automatically if the bottom of the pan is not flat or if the pan is too large or too small for the element. This will result in longer cooking times.

Solid elements hold heat longer than conventional surface units. For best cooking results, use a high setting for only a short period of time. Then use a lower setting to complete the cooking. You may want to turn the solid element surface unit OFF a few minutes before you finish cooking.

⚠ WARNING

Burn, Fire and Personal Property Damage Hazard

- **Be sure all control knobs are turned to OFF and all indicator lights are OFF when you are not cooking. Someone could be burned or a fire could start if a surface unit is accidentally left ON.**
- **Solid elements stay hot for a long time. Do not use the HI setting for long periods of time or leave pans on hot elements when cooking is done. Burned food and damage to the cookware could result.**

Cookware

Pans should be the same size or larger than the surface unit to prevent boil-overs and hot handles.

Use only flat-bottomed utensils. Flat bottoms allow maximum contact between the pans and surface units for fast, even cooking. Pans with uneven bottoms or with raised patterns on the bottoms are not suitable. **Do not use trivets, woks with skirts, or canners with concave or ridged bottoms.**

To check your cookware for flatness, place a straight-edge across the bottom of each piece. Rotate the straight-edge across the bottom. If light shows anywhere between the pan and the straight-edge, the pan is not flat. Do not use it.

See the Cooking Guide for additional cookware information.

⚠ WARNING

Burn Hazard

If the pan is too small for the surface unit, you could be burned by the heat from the exposed section of the surface unit. Use correctly sized utensils to prevent injury.

Setting the Clock

Push in and turn the Minute Timer Knob to set the Clock.

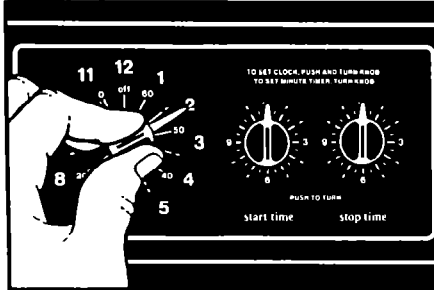

1. Push in Minute Timer Knob and turn clockwise until clock shows the right time of day.

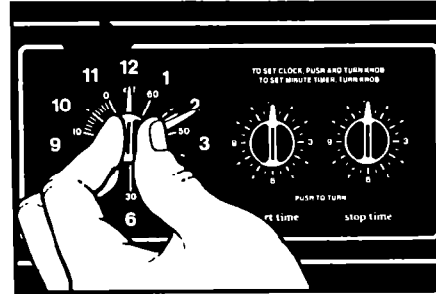

2. Let the Minute Timer Knob pop out. Turn clockwise until Minute Timer hand points to OFF. The clock setting will change if you push in the knob when turning.

Using the Minute Timer

The Minute Timer does not start or stop the oven. It works like a kitchen timer. Set it in minutes up to an hour. You will hear a buzzer when the set time is up.

DO NOT PUSH IN THE KNOB when setting the Minute Timer.

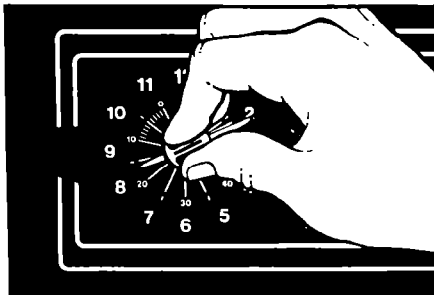

1. Without pushing it in, turn the Minute Timer Knob until the timer hand passes the setting you want.

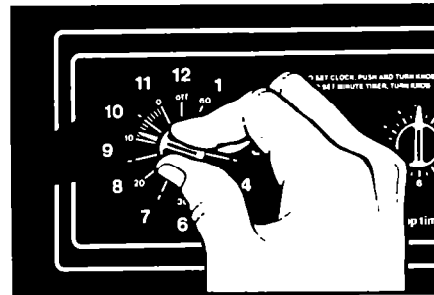

2. Without pushing in, turn the knob back to the setting you want. When the time is up, a buzzer will sound. To stop the buzzer, turn the Minute Timer hand to OFF.

PUSHING IN AND TURNING THE MINUTE TIMER KNOB CHANGES THE CLOCK SETTING.

Using the Oven Controls

Baking

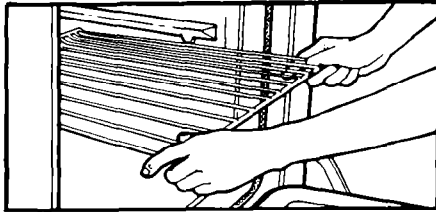

1. Position the rack(s) properly **before** turning on the oven. **To change rack position**, lift rack at front and pull out.

The rack(s) should be placed so the top of the food will be centered in the oven. Always leave at least 1½ to 2 inches (4-5 cm) between the sides of the pan and the oven walls and other pans. For more information, see the Cooking Guide.

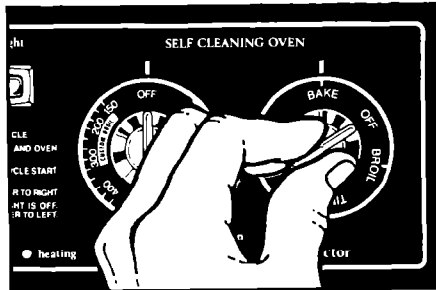

2. Set the Oven Selector on BAKE. The Oven ON Indicator Light will come on.

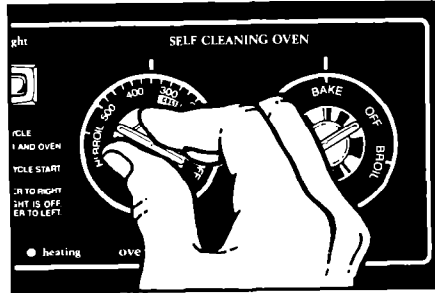

3. Set the Oven Temperature Control to the baking temperature you want. The Oven HEATING Indicator Light will come on. The oven is pre-heated when the Oven HEATING Indicator Light first goes off.

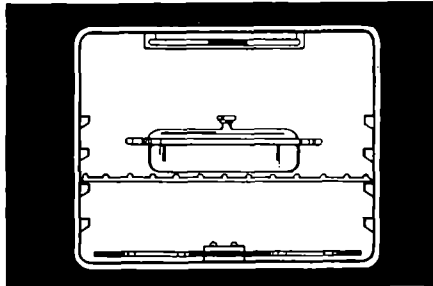

4. Put food in the oven. During baking, the elements will turn on and off to keep the oven temperature at the setting. The Oven HEATING Indicator Light will turn on and off with the elements.

The top element helps heat during baking, but does not turn red.

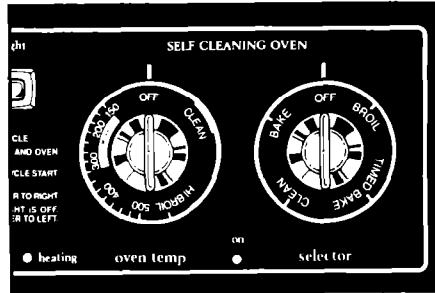

5. When baking is done, turn **both** the Oven Selector and Oven Temperature Control to OFF. The Oven HEATING and ON Indicator Lights will go OFF.

Adjusting the Oven Temperature Control

Does your oven seem hotter or colder than your old oven? The temperature of your old oven may have shifted gradually without your noticing the change. Your new oven is properly adjusted to provide accurate temperatures. But when compared to your old oven, the new design may give you different results.

If after using the oven for a period of time, you are not satisfied with the temperature settings, they can be adjusted by following these steps:

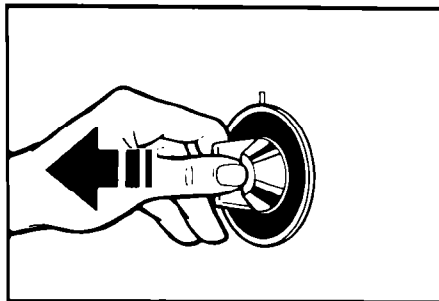

- 1.** Pull the Oven Temperature Control Knob straight off.

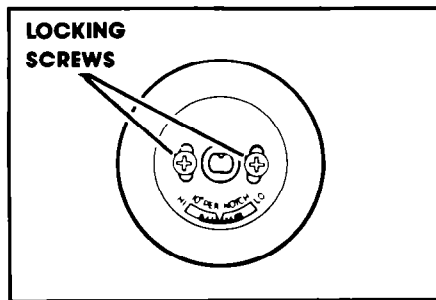

- 2.** Loosen the locking screws inside the control knob. **Note the position of the notches.**

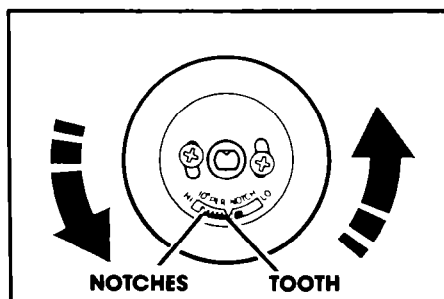

- 3.** To lower the temperature, move the tooth a notch closer to LO. Each notch equals about 10°F (5°C).

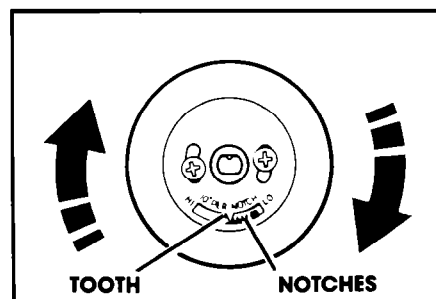

- 4.** To raise the temperature, move the tooth a notch closer to HI. Each notch equals about 10°F (5°C).

Tighten the locking screws and replace the control knob.

Broiling

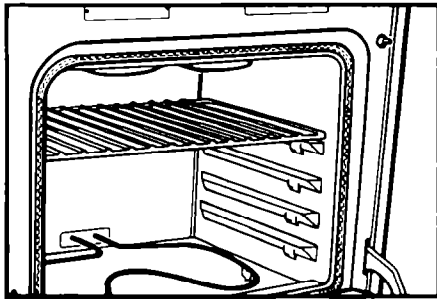

1. Position the rack before turning the oven on. See "Broil Chart" in the Cooking Guide or a reliable cookbook for recommended rack positions.

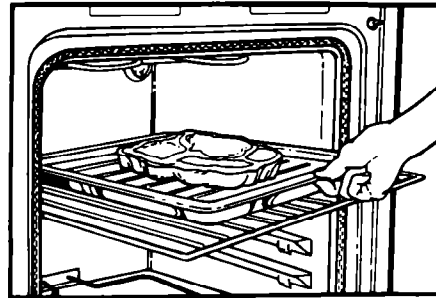

2. Put the broiler pan and food on the rack.

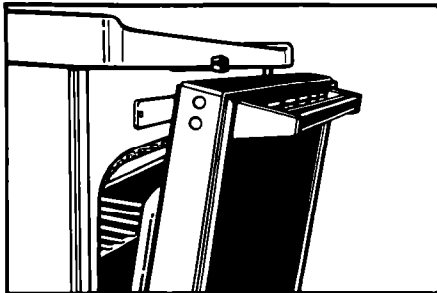

3. Close the door to the Broil Stop position (open about 4 inches, 10.2 cm). The door will stay open by itself.

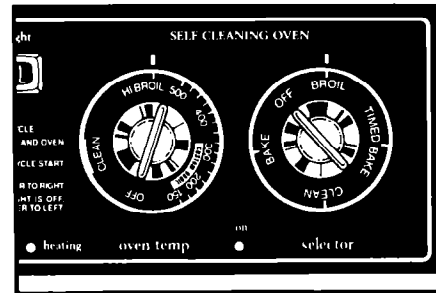

4. Set the Oven Selector and Oven Temperature Control to BROIL. The Oven ON and HEATING Indicator Lights will come on.
5. When broiling is done, turn **both** the Oven Selector and Oven Temperature Control to OFF. The Oven ON and HEATING Indicator Lights will go off.

Custom Broil

- If food is cooking too fast, turn the Oven Temperature Control **counterclockwise** until the Oven HEATING Indicator Light goes off.
- If you want the food to broil slower from the start, set the Oven Temperature Control between 150° and 325°F (65.5° and 162.7°C). The lower the temperature, the slower the cooking.

The Oven Selector must be on BROIL for all broiling temperatures.

NOTE: The door must be partly open whenever the oven is set to BROIL. Leaving the door open allows the oven to maintain proper temperatures.

Using The Automatic MEALTIMER™ Clock

The automatic MEALTIMER™ Clock is designed to turn the oven on and off at times you set, even when you are not around.

Automatic baking is ideal for foods which do not require a preheated oven, such as meats and casseroles. **Do not use the automatic cycle for cakes, cookies, etc...undercooking will result.**

To delay start and stop automatically:

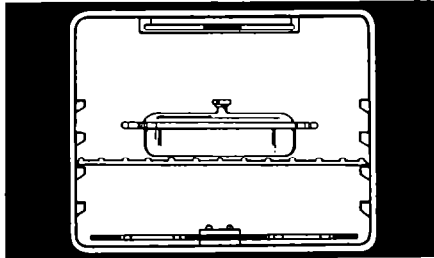

1. Position the oven rack(s) properly and place the food in the oven.

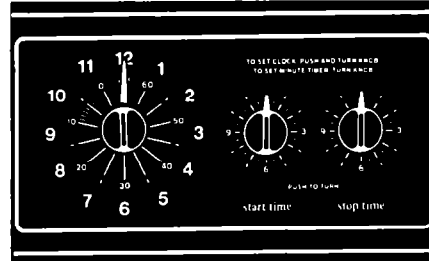

2. Make sure the clock is set to the right time of day.

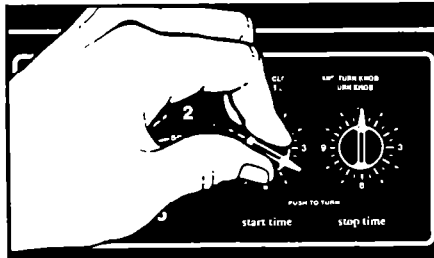

3. Push in and turn the Start Time Knob **clockwise** to the time you want baking to start.

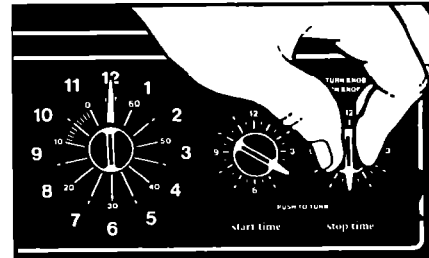

4. Push in and turn the Stop Time Knob **clockwise** to the time you want the oven to shut off.

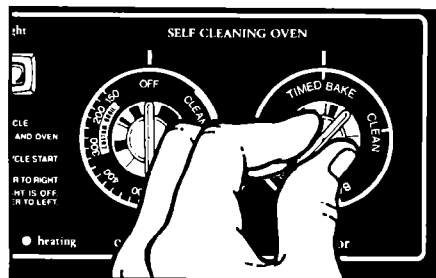

5. Set the Oven Selector on **TIMED BAKE**. The Oven ON Indicator Light will come on.

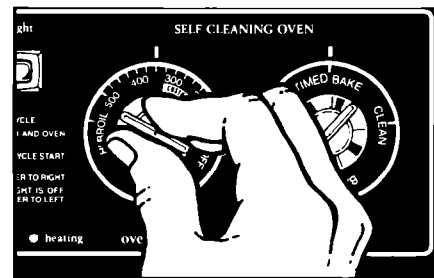

6. Set the Oven Temperature Control on the baking temperature you want. The oven will now start and stop automatically. The Oven **HEATING** Indicator Light will come on.

7. **After baking is done or to stop the oven before preset time**, turn both the Oven Selector and the Oven Temperature Control to **OFF**.

To start baking now and stop automatically:

- 1.** Position rack(s) properly and place the food in the oven.
- 2. Make sure the clock is set to the right time of day.**
- 3.** Push in and turn the Stop Time Knob **clockwise** to the time you want the oven to shut off. Make sure the Start Time Knob is out.
- 4.** Set the Oven Selector on TIMED BAKE.
- 5.** Set the Oven Temperature Control on the baking temperature you want.
- 6. After baking is done or to stop the oven before the preset time,** turn both the Oven Selector and the Oven Temperature Control to OFF.

⚠ WARNING**To avoid sickness and food waste when using the MEALTIMER™ control:**

- **Do not use foods that will spoil while waiting for cooking to start, such as dishes with milk or eggs, cream soups, and cooked meats or fish. Any food that has to wait for cooking to start should be very cold or frozen before it is put in the oven. MOST UNFROZEN FOODS SHOULD NEVER STAND MORE THAN TWO HOURS BEFORE COOKING STARTS.**
- **Do not use foods containing baking powder or yeast when using delay start. They will not rise properly.**
- **Do not allow food to remain in oven for more than two hours after end of cooking cycle.**

The Oven Vent

Hot air and moisture escape from the oven through a vent on the backguard below the control panel. The vent is needed for air circulation. **Do not block the vent.** Poor baking can result.

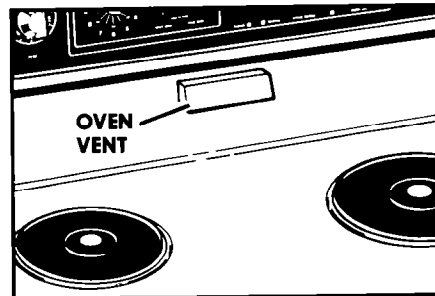
**⚠ WARNING****Burn Hazard**

When the oven is ON, pans and pan handles left near the oven vent can become hot enough to burn the user and to melt plastics. Use potholders to move pans. Never store plastics, paper or other items that could melt or burn near the oven vent, or any of the surface units.

The Storage Drawer

The storage drawer is for storing pots and pans. The drawer can be removed to make it easier to clean under the range.

Use care when handling the drawer.

Removing the Storage Drawer

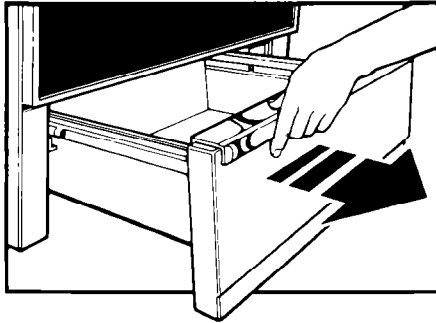

- 1.** Empty drawer of any pots and pans before removing drawer. Pull drawer straight out to the first stop. Lift front and pull out to the second stop.

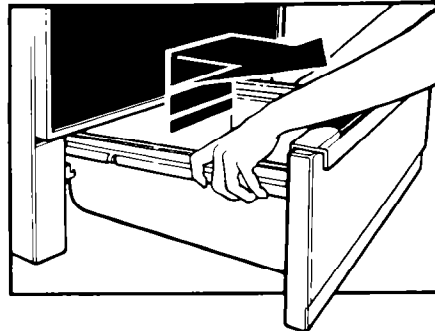

- 2.** Lift back slightly and slide drawer all the way out.

Replacing the Storage Drawer

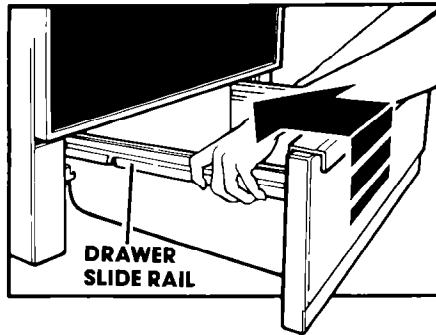

- 1.** Fit ends of drawer slide rails into the drawer guides on both sides of opening.

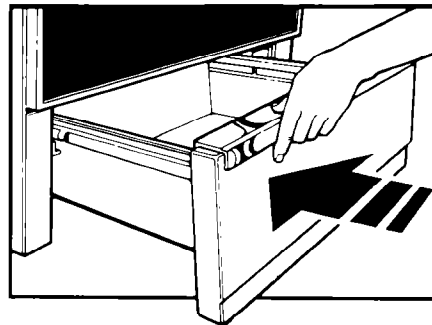

- 2.** Lift drawer front and push in until metal stops on drawer slide rails clear white stops on drawer guides. Lift drawer front again to clear second stop and slide drawer closed.

Optional Rotisserie

If you would like a rotisserie for your oven, you can order a kit (Part No. 242985) from your Whirlpool Dealer. The kit includes easy installation instructions.

Optional Door Panel Pac

If you would like to change the color of your oven door glass to white or almond, you can order one of these kits from your Whirlpool Dealer: for Model RF377PXW, White (Kit No. 814069) or Almond (Kit No. 814070); for Model RF367BXW, White (Kit No. 814071) or Almond (Kit No. 814072). The kits include easy installation instructions.

Caring for your range

Control Panel and Knobs

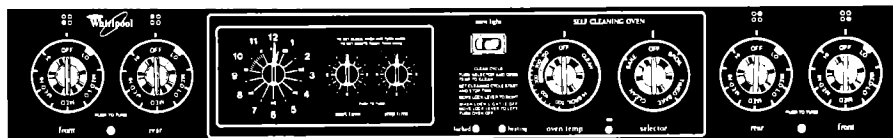

⚠ WARNING

Burn and Electrical Shock Hazard
Make sure all controls are OFF and the range is cool before cleaning. Failure to do so can result in burns or electrical shock.

1. Pull knobs straight off.
2. Use warm soapy water and a soft cloth, or spray glass cleaner, to wipe the control panel. Rinse and wipe dry.
3. Wash control knobs in warm soapy water. Rinse well and dry. Do not soak.
4. Push control knobs straight back on. Make sure they point to OFF.

WHIRLPOOL RANGE CLEANING FOR YOUR RANGE

Solid Element Surface Units

⚠ WARNING

Burn and Electrical Shock Hazard

Solid element surface units do not glow red when hot. Make sure all controls are OFF and the range is COOL before cleaning. Failure to do so can result in burns or electrical shock.

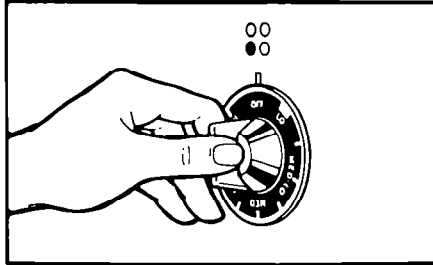

1. Turn off all surface units.

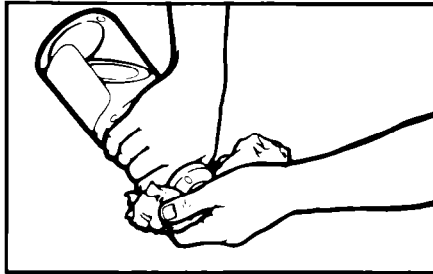

3. **IMPORTANT:** Dry the element completely after cleaning. Turn on the element for a few minutes to thoroughly dry. After the element has cooled, use a paper towel to apply a thin coat of salt-free oil to the surface units to season and restore the finish. Wipe excess oil off stainless steel trim rings. Then heat 3-5 minutes. Some smoking may occur; this is normal. If surface units have dark spots caused by grease and food, the oil treatment will improve their appearance but not eliminate the spots. **NOTE: Optional Electrol® dressing can be applied to the surface units to improve their appearance.**

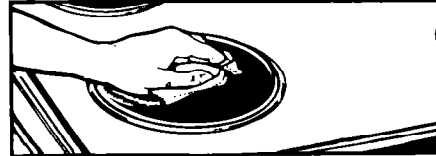

2. For best results, wipe off surface units with a damp soft cloth and soapy water after each use. Remove burned-on food with a soap-filled scrubbing pad. Rinse well. The red spot in the center of the surface unit will gradually wash off. This is normal and will not affect the operation of the surface unit. **NOTE: Make sure plastic scrubbing pad does not contain metal or abrasive particles. Do not use abrasive cleaners.**

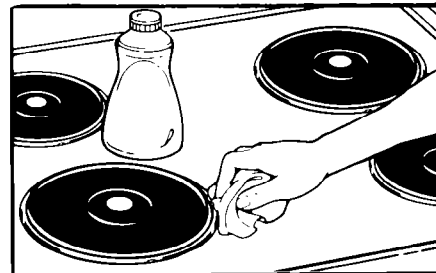

4. The stainless steel trim rings will gradually yellow from the heat of the surface units and pans. This is normal. The yellowing can be removed by using stainless steel cleaner or Cook Top Polishing Creme on the trim rings.

To obtain order information for Cook Top Polishing Creme (Part No. 814009) or Electrol® dressing (Part No. 814030), write to:

Whirlpool Corporation
Attention: Customer Service Dept.
1900 Whirlpool Drive
LaPorte, IN 46305

Using the Self-Cleaning Cycle

The Self-Cleaning cycle uses **very high heat** to burn away soil. Before you start, make sure you understand exactly how to use the Self-Cleaning cycle safely.

Before You Start

1. Clean the areas shown by hand.

They do not get hot enough during the Self-Cleaning cycle for soil to burn away. Use hot water and detergent or a soapy steel wool pad on...

- The inside of the door. (The center area of the door does not need to be hand cleaned.)
- The frame around the oven.

DO NOT clean, move or bend the fiberglass seal. Poor cleaning and poor baking will result.

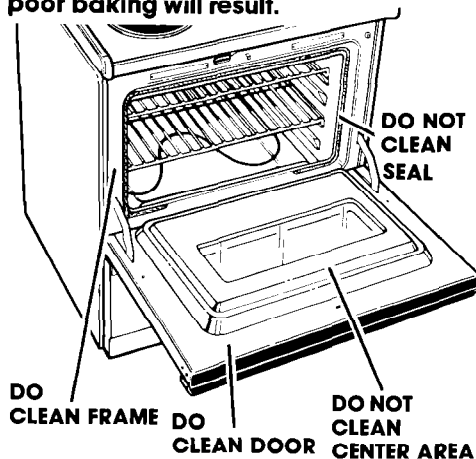

2. Remove the broiler pan and any pots and pans you may have stored in the oven.

NOTE: The broiler pan (without grid) can be cleaned in the oven only if most of the soil has been removed by hand-cleaning or a dishwasher. The chrome broiler grid will discolor if cleaned in the Self-Cleaning cycle.

3. Wipe out any loose soil or grease. This will help reduce smoke during the Self-Cleaning cycle.

4. If the oven has a rotisserie, make sure the motor socket cover is closed.

5. If you want the oven racks to remain shiny, remove from the oven and clean by hand. Otherwise, put oven racks on second and fourth guides (guides are counted from bottom to top). After racks are cleaned in the Self-Cleaning cycle, they become harder to slide. Apply a small amount of vegetable oil to the sides of the racks to make them easier to slide. See chart on page 20.

Turn on the vent hood or other kitchen vent during the Self-Cleaning cycle. This will help remove heat and odors that are normal during the cycle.

⚠ WARNING

Personal Injury and Product Damage Hazard

- Do not touch the oven during the Self-Cleaning cycle. It could burn you.
- Do not use commercial oven cleaners in your oven. Cleaners may produce hazardous fumes or damage the porcelain finish.
- Do not force the Lock Lever, you could bend or break it. The lever is designed to stay locked until the oven is cool enough to safely open. Wait until it moves freely.
- Do not use foil or other liners in the oven. During the Self-Cleaning cycle foil can burn or melt and damage the oven surface.
- Do not block the vent during the Self-Cleaning cycle. Air must move freely for best cleaning results.
- Do not leave plastic utensils near the vent. They may melt.

Setting the Controls

Be sure the kitchen is ventilated during the Self-Cleaning cycle. This will help heat, odors and smoke to disappear from the room as quickly as possible.

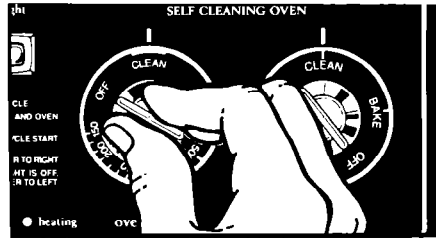

1. Set the Oven Selector and Oven Temperature Control on CLEAN.

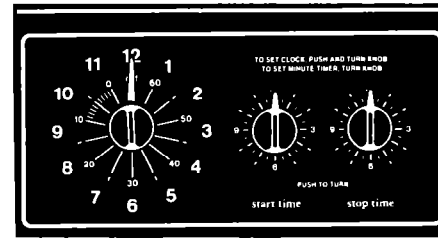

2. Make sure the Clock, Start and Stop Times all have the right time of day.

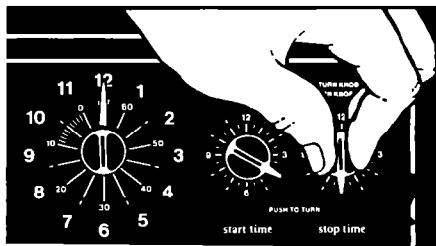

3. Push in and turn the Stop Time Knob **clockwise** 2 or 3 hours.
 - Use 2 hours for light soil.
 - Use 3 hours or more for moderate to heavy soil.

NOTE: Make sure the Start Time Knob is out.



5. The Oven **LOCKED** Indicator Light comes on when the oven temperature exceeds normal baking temperatures. The Lock Lever must not be moved and the door can't be opened when the Oven **LOCKED** Indicator Light is on.

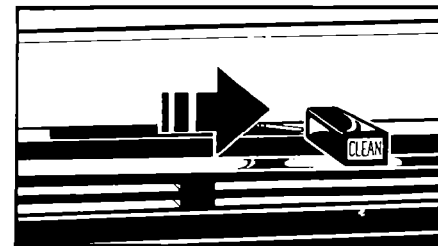

4. Move the Lock Lever to the right – the Clean position. The Oven **HEATING** and **ON** Indicator Lights will come on.

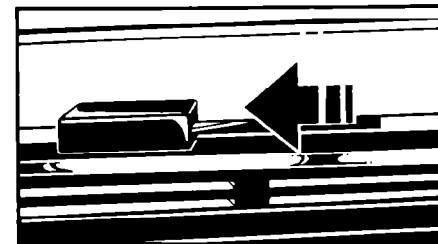

6. **After the Self-Cleaning cycle is completed**, the Oven **LOCKED** Indicator Light goes off when the oven reaches normal baking temperatures. Move the Lock Lever back to the left. **Do not force it.** Wait until it moves easily. Turn the Oven Selector and Oven Temperature Control to OFF.

7. **After the oven is cool**, wipe off any residue or ash with a damp cloth. If needed, touch up spots with a soapy steel wool pad.

Special Tips

- Keep the kitchen well ventilated during the Self-Cleaning cycle to help get rid of heat, odors and smoke.
- Clean the oven before it gets heavily soiled. Cleaning a very soiled oven takes longer and results in more smoke than usual.
- If the Self-Cleaning cycle doesn't get the oven as clean as you expected, the cycle may not have been set long enough or you may not have prepared the oven properly. Set the Self-Cleaning cycle longer the next time and hand clean areas noted on page 17.

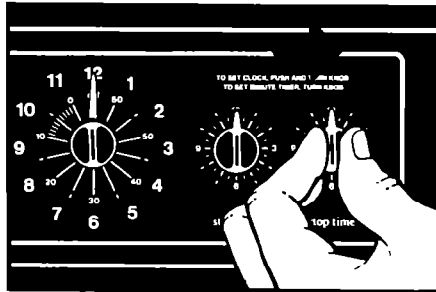

To stop the Self-Cleaning cycle at anytime:

1. Push in and turn the Stop Time Knob **clockwise** until it points to the right time of day.

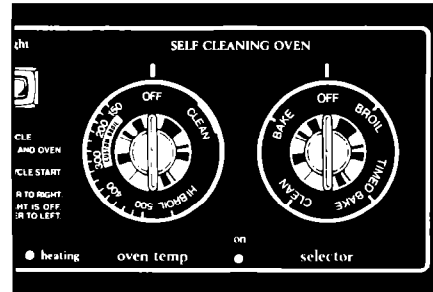

2. Turn the Oven Selector and Oven Temperature Control to OFF. When the Oven LOCKED Indicator Light goes off, move the Lock Lever back to the left. **DO NOT FORCE IT.** Wait until it moves easily.

⚠ WARNING

Burn Hazard
Do not touch the range during the Self-Cleaning cycle. It can burn you.

How It Works

During the Self-Cleaning cycle, the oven gets much hotter than it does for baking or broiling...approximately 875°F (468°C). This heat breaks up grease and soil and burns it off.

This graph shows approximate temperatures and times during a Self-Cleaning cycle for 3 hours.

SELF-CLEANING CYCLE – THREE HOUR SETTING

(Approximate Temperatures and Times)

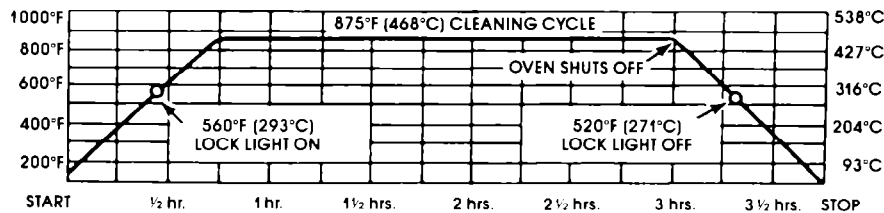

Notice that the heating stops when the 3-hour setting is up, but that it takes longer for the oven to cool down enough to unlock.

Cleaning Chart

PART	WHAT TO USE	HOW TO CLEAN
Exterior surfaces	Warm soapy water and a soft cloth. Plastic scrubbing pad for heavily-soiled areas.	<ul style="list-style-type: none"> Wipe off regularly when oven is cool. Do not allow food containing acids (such as vinegar, tomato, lemon juice or milk) to remain on surface. Acids may remove the glossy finish. Do not use abrasive or harsh cleansers.
Surface units (Solid elements)	Warm, soapy water and a soft cloth. Soap-filled scrubbing pad. (See "Solid Element Surface Units" on page 16 for more information.)	<ul style="list-style-type: none"> Make sure the cooktop and the surface units are cool. Wipe off the surface units after each use. Make sure all soap residue is removed. After each cleaning, heat surface units until dry.
	To darken surface units or to remove rust spots:	
	Salt-free oil on a soft cloth.	<ul style="list-style-type: none"> Make sure surface units are cool. After each cleaning, apply thin coat of oil to surface units, then heat for 3-5 minutes. Slight smoking of oil will occur.
	Electrol [®] dressing (Part No. 814030)*	<ul style="list-style-type: none"> Follow the directions on the dressing. NOTE: This will improve surface unit appearance, but not eliminate dark spots.
(Trim rings)	Stainless steel cleaner or Cook Top Polishing Creme. (Part No. 814009)* NOTE: Yellowing of trim rings is normal from heat of the surface units and pans.	<ul style="list-style-type: none"> Make sure surface units are cool. Follow directions provided with cleaner or polishing creme.
Control knobs	Warm soapy water and a soft cloth.	<ul style="list-style-type: none"> Wash, rinse and dry well. Do not soak.
Control panel	Warm soapy water or spray glass cleaner and a soft cloth.	<ul style="list-style-type: none"> Wash, rinse and dry well. Follow directions provided with the cleaner.
Broiler pan and grid	Warm soapy water or a soapy steel wool pad.	<ul style="list-style-type: none"> Clean after each use. Wash, rinse and dry well. Do not clean in Self-Cleaning Oven. (See note on page 17.)
Oven racks	Self-Cleaning cycle. Warm soapy water or soapy steel wool pads.	<ul style="list-style-type: none"> Leave in oven during Self-Cleaning cycle. OR Wash, rinse and dry. Use soapy steel wool pads for heavily-soiled areas.
	NOTE: The oven racks will discolor and be harder to slide when left in the oven during the Self-Cleaning cycle. If you want them to stay shiny, remove from the oven and clean by hand.	

PART	WHAT TO USE	HOW TO CLEAN
Oven door glass (Model RF377PXW only)	Spray glass cleaner or warm soapy water and a plastic scrubbing pad.	<ul style="list-style-type: none"> • Make sure oven is cool. • Follow directions provided with the cleaner. • Wash, rinse and dry well.
Self-Cleaning Oven	For areas outside the Self-Cleaning area use warm soapy water or soapy steel wool pads.	<ul style="list-style-type: none"> • Follow directions starting on page 17, "Using the Self-Cleaning Cycle." • Do not use commercial oven cleaners. • Do not use foil to line the bottom of your Self-Cleaning Oven.

The Oven Light

The oven light will come on when you open the oven door. **Model RF377PXW only:** To turn the light on when the oven door is closed, push the Oven Light Switch on the control panel. Push it again to turn off the light.

To Replace:

⚠ WARNING

Electrical Shock and Personal Injury Hazard

- **Make sure oven and light bulb are cool and power to the oven has been turned OFF before replacing the light bulb. Failure to do so could result in electrical shock or burns.**
- **The bulb cover must be in place when using the oven. The cover protects the bulb from breaking, and from high oven temperatures. Broken glass could cause injury.**

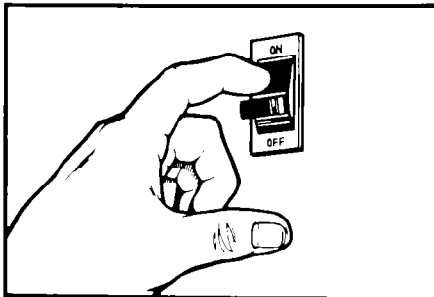

1. Unplug appliance or disconnect at the main power supply.

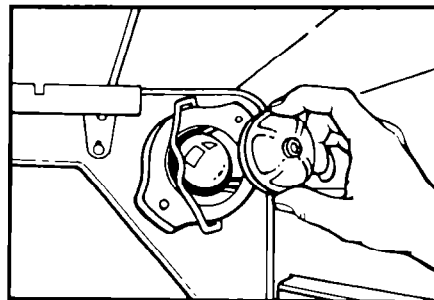

2. Remove the bulb cover in the back of the oven by pulling out and pushing the wire holder to the side.

continued on next page

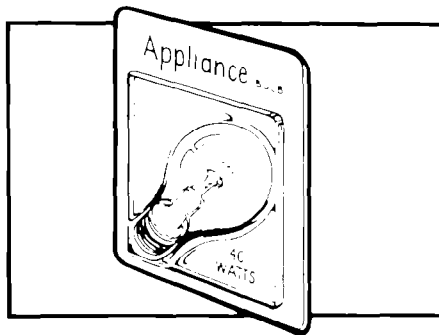

- 3.** Remove the light bulb from its socket. Replace the bulb with a 40-watt appliance bulb.

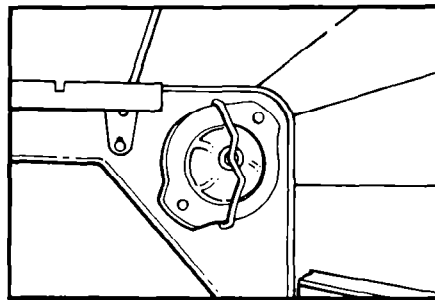

- 4.** Replace the bulb cover and snap the wire holder in place. Plug in appliance or reconnect at the main power supply.

NOTE: The oven light will not work during the Self-Cleaning cycle.

If you need service or assistance, we suggest you follow these steps:

1. Before calling for assistance...

Performance problems often result from little things you can find and fix without tools of any kind.

If nothing operates:

- Is the power supply cord plugged into a live circuit with the proper voltage? (See Installation Instructions.)
- Have you checked your home's main fuses or circuit breaker box?

If the oven will not operate:

- Is the Oven Selector turned to a setting (BAKE or BROIL, but not TIMED BAKE)?
- Is the Oven Temperature Control turned to a temperature setting?
- Is the automatic MEALTIMER™ Clock set correctly?

If surface units will not operate or seem to cook too slow:

- Have you checked your home's main fuses or circuit breaker box?
- Is the surface unit control knob turned to a setting other than OFF?
- Are you using the proper cookware? See page 7.
- Do the control knobs turn?

If surface unit control knob(s) will not turn:

- Did you push in before trying to turn?

If the Self-Cleaning cycle will not operate:

- Are the Oven Selector and Oven Temperature Control set on CLEAN?
- Does the Start Time Dial show the correct time of day? Is the knob all the way out?
- Is the Stop Time Dial set ahead to the time you want the cleaning cycle to stop?
- Is the Lock Lever all the way to the right?

If cooking results aren't what you expected:

- Is the range level?
- Does the oven temperature seem too low or too high? See page 10.
- If needed, have you preheated the oven as the recipe calls for?
- Are you following a tested recipe from a reliable source?
- Are you using pans recommended in the Cooking Guide?
- If baking, have you allowed 1½ to 2 inches (4-5 cm) on all sides of the pans for air circulation?
- Are the pans the size called for in the recipe?
- Do the cooking utensils have smooth, flat bottoms and fit the surface elements being used?

See the Cooking Guide for more information on cooking problems and how to solve them.

2. If you need assistance*...

Call Whirlpool COOL-LINE® service assistance telephone number. Dial free from anywhere in the U.S.: 1-800-253-1301

and talk with one of our trained consultants. The consultant can instruct you in how to obtain satisfactory operation from your appliance or, if service is necessary, recommend a qualified service company in your area.

If you prefer, write to:

Mr. Donald Skinner
Director of Consumer Relations
Whirlpool Corporation
2000 M-63
Benton Harbor, MI 49022

Please include a daytime phone number in your correspondence.

3. If you need service*...



Whirlpool has a nationwide network of authorized WhirlpoolSM service companies. Whirlpool service technicians are trained to fulfill the product warranty and provide after-warranty service, anywhere in the United States. To locate the authorized Whirlpool service company in your area, call our COOL-LINE® service assistance telephone number (see Step 2) or look in your telephone directory Yellow Pages under:

APPLIANCES - HOUSEHOLD - ELECTRICAL APPLIANCES -
MAJOR - SERVICE & REPAIR MAJOR - REPAIRING & PARTS

OR

WASHING MACHINES, DRYERS
& IRONERS - SERVICING

WHIRLPOOL APPLIANCES
AUTHORIZED WHIRLPOOL SERVICE

SERVICE COMPANIES

XYZ SERVICE CO
123 MAPLE 999-9999

4. If you need FSP® replacement parts*...

FSP is a registered trademark of Whirlpool Corporation for quality parts. Look for this symbol of quality whenever you need a replacement part for your Whirlpool appliance. FSP replacement parts will fit right and work right, because they are made to the same exacting specifications used to build every new Whirlpool appliance.

To locate FSP replacement parts in your area, refer to Step 3 above or call the Whirlpool COOL-LINE service assistance number in Step 2.

5. If you are not satisfied with how the problem was solved*...

- Contact the Major Appliance Consumer Action Panel (MACAP). MACAP is a group of independent consumer experts that voices consumer views at the highest levels of the major appliance industry.
- Contact MACAP only when the dealer, authorized servicer or Whirlpool have failed to resolve your problem.
Major Appliance Consumer
Action Panel
20 North Wacker Drive
Chicago, IL 60606
- MACAP will in turn inform us of your action.

*When requesting assistance, please provide: model number, serial number, date of purchase, and a complete description of the problem. This information is needed in order to better respond to your request.

WHIRLPOOL® RANGE PRODUCT WARRANTY

ER001

LENGTH OF WARRANTY	WHIRLPOOL WILL PAY FOR
FULL ONE-YEAR WARRANTY From Date of Purchase	FSP® replacement parts and repair labor to correct defects in materials or workmanship. Service must be provided by an authorized Whirlpool SM service company.
WHIRLPOOL WILL NOT PAY FOR	
<p>A. Service calls to:</p> <ol style="list-style-type: none"> 1. Correct the installation of the range product. 2. Instruct you how to use the range product. 3. Replace house fuses or correct house wiring or plumbing. 4. Replace owner accessible light bulbs. <p>B. Repairs when range product is used in other than normal, single-family household use.</p> <p>C. Pick up and delivery. This product is designed to be repaired in the home.</p> <p>D. Damage to range product caused by accident, misuse, fire, flood, acts of God or use of products not approved by Whirlpool.</p>	

WHIRLPOOL CORPORATION SHALL NOT BE LIABLE FOR INCIDENTAL OR CONSEQUENTIAL DAMAGES. Some states do not allow the exclusion or limitation of incidental or consequential damages so this limitation or exclusion may not apply to you. This warranty gives you specific legal rights, and you may also have other rights which vary from state to state.

Outside the United States, a different warranty may apply. For details, please contact your franchised Whirlpool distributor or military exchange.

If you need service, first see the "Service and Assistance" section of this book. After checking "Service and Assistance," additional help can be found by calling our COOL-LINE® service assistance telephone number, **1-800-253-1301**, from anywhere in the U.S.



Part No. 3149916 Rev. A
 ©1990 Whirlpool Corporation

Printed in U.S.A.

ce Makers. Dishwashers. Built-In Ovens and Surface Units. Ranges. Microwave Ovens. Trash Compactors. Room Air Conditioners. Dehumidifiers. Automatic

